

# MT80-FIR40-Fio-xx

## AO FIBRE PIGTAILED MODULATORS/SHIFTERS For 1850-2100 nm



### Product Overview

This fibre pigtailed device is optimized for a single wavelength within the range of operation [1850-2100] nm and it must be specified on order. It can operate for intensity modulation, fixed or variable frequency shifting, pulse picking or q-switching.

Available with PM or SM fibres, low power version or high power version up to 5W depending on models.

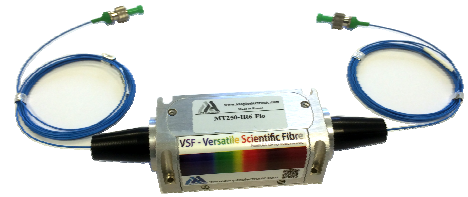

### Features

- Polarization Maintaining or Single Mode fibre
- FC/APC
- Positive frequency shift (negative on request)
- High Extinction Ratio

Access to your operating manual



TECHNICAL DATA SHEET 2015

### Technical Specifications

Parameters	MT80-FIR40-Fio-xx
Material-Acoustic mode-Velocity	TeO <sub>2</sub> - [L] - 4200 m/s
Optical Wavelength range	1850 to 2100, AR coated
IL, Insertion Losses	Nom 4 dB, <6dB
Input / Output Polarization	Linear (PM fibres), Random (SM fibres)
PDL, Polarization Dependence Losses	< 1 dB
Carrier frequency / Frequency shift	+80 MHz
Static Extinction Ratio	> 45 dB, nom 50 dB
Fibre type (SM / PM)	SM1950 or PM1950
Jacket type	HYTREL 900 µm
Fibre connectors	FC/APC
Pigtail length	1 meter (IN/OUT)
Rise/Fall time	Nom 30 ns, <40 ns
Analog modulation BW (-3dB)	<12 MHz
Max Input laser power (CW)	0.5 W or 5 W
Input impedance	Nom 50 Ω
V.S.W.R.	Nom < 1.2/1
RF Power / Connector	< 2.5 W / SMA
Size / Weight	(LxIxh) 89 x 46.6 x 32.5 mm <sup>3</sup> / 250 g IN PRO 334
Operating Temperature	+10 to +40°C, Non condensing
Storage Temperature	-40 to +50°C, Non condensing

### Options / On request

FIBER JACKET	<input checked="" type="checkbox"/> PVC 3 mm	<input checked="" type="checkbox"/> Stainless steel 3 mm
FIBER CONNECTOR	<input checked="" type="checkbox"/> Super FC/PC	<input checked="" type="checkbox"/> SMA
PIGTAIL LENGTH	<input checked="" type="checkbox"/> 2 m	<input checked="" type="checkbox"/> Other
FREQUENCY SHIFT	<input checked="" type="checkbox"/> « - » Negative shift	<input checked="" type="checkbox"/> Variable frequency shift

**Rise Time (Tr)** is beam diameter ( $\Phi$ ) sensitive:

$$Tr = 0.66 \frac{\Phi}{V}$$

**Insertion Loss (IL)** is the amount of launched light lost within the Acousto-Optic Modulator (AOM). It is defined as the ratio of the input optical power over the output optical power.

The value of IL indicated in datasheet includes optical transmission through the crystal, diffraction efficiency and coupling losses. Losses at FC connectors are not included.

**Polarization dependent loss (PDL)** is when the insertion loss of a signal differs between the two different states of polarization. Polarization Dependent Loss is a measure of the peak-to-peak difference in Transmission of the AOM with respect to all possible states of polarizations.

It is defined as the ratio between the maximum and minimum transmission power with respect to all possible axes of polarization.

The PDL of the acousto-optic devices is mainly due to the polarization dependency of the diffraction efficiency.

**Amplitude modulation bandwidth (F<sub>-3dB</sub>)** is rise time (Tr) sensitive:

$$F_{-3dB} = \frac{0.48}{Tr}$$

**RF power (P)** is wavelength ( $\lambda$ ) sensitive:

$$\frac{P_1}{P_2} = \frac{\lambda_1^2}{\lambda_2^2}$$

**PMD (Polarization Mode Dispersion)** is the differential arrival time of the different polarization components of an input light pulse, transmitted by the AOM. This light pulse can always be decomposed into pairs of orthogonal polarization modes. These polarization modes propagate at different speeds according to a slow and fast axis induced by the birefringence of the AOM.

**Second Order PMD:** The second order PMD describes how polarization induced delay, varies with wavelength. It provides the indication of the wavelength dependency of the PMD.

**Relative Efficiency versus RF power**

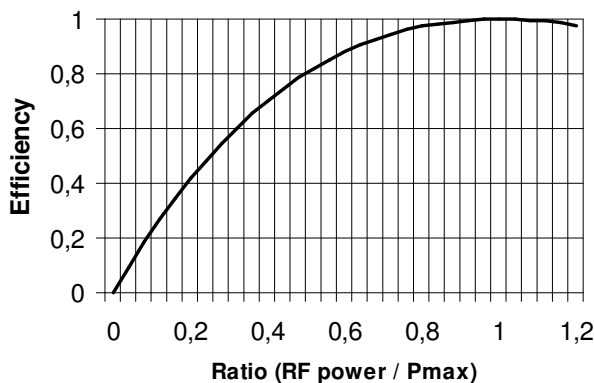

**AO relative Efficiency vs driver MOD IN**

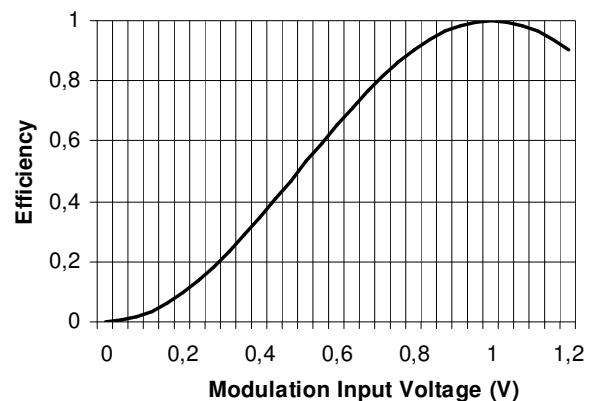

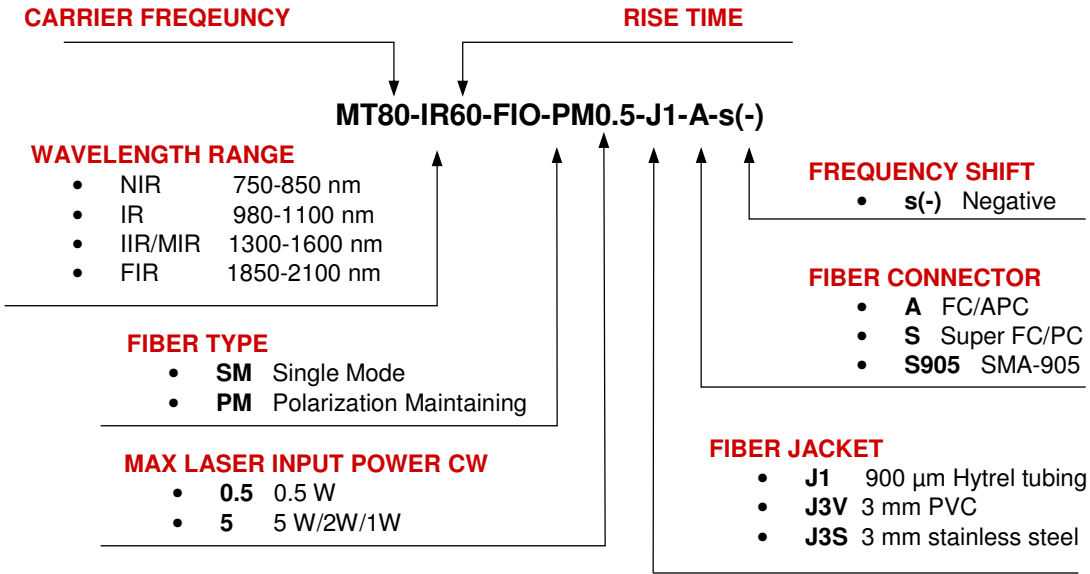

Relative Efficiency / AOM temporal response

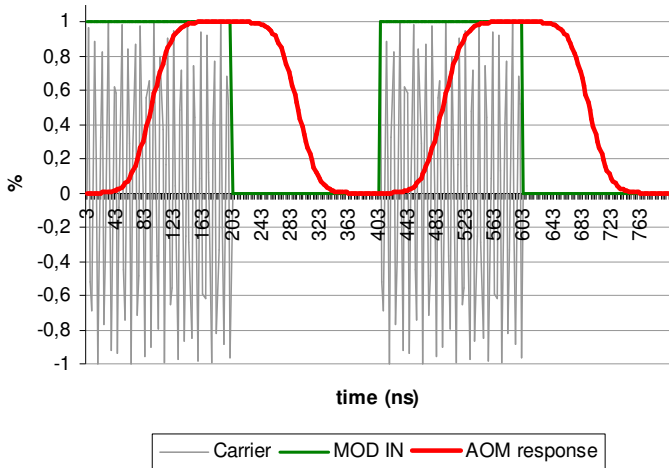

Relative Efficiency / AOM temporal response (1MHz)

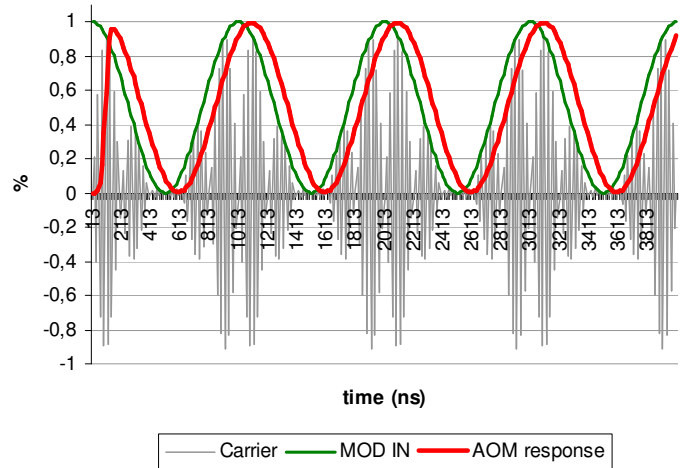

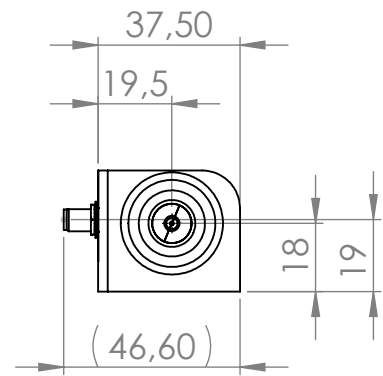
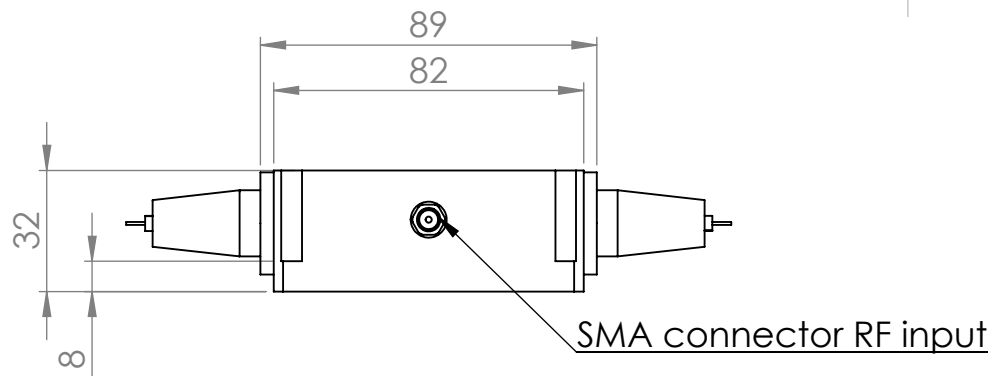

4x FIXING HOLES FOR SCREWS M2.5

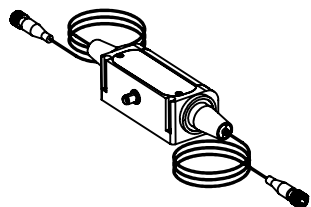
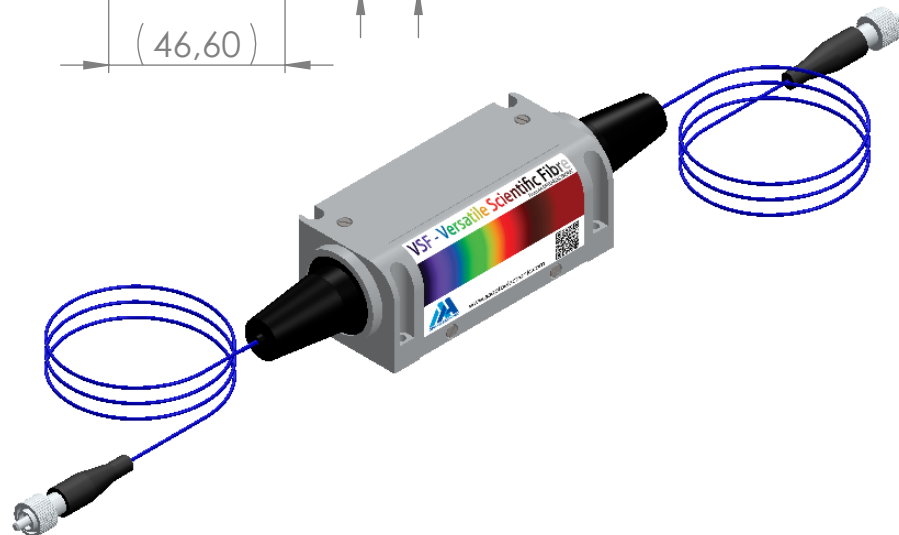
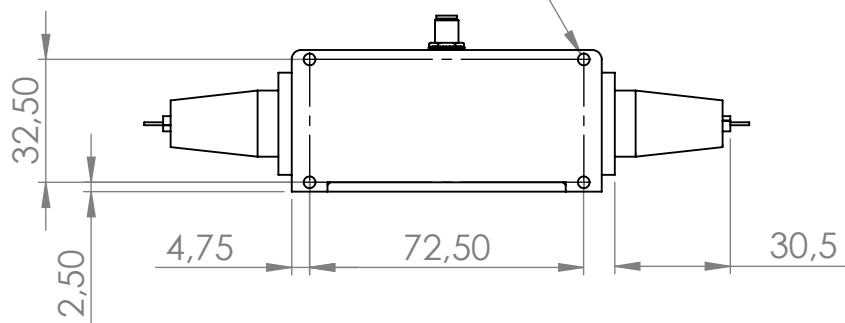

A	17/12/14	G.M	Plan initial / Initial plan		
Indice Index	Date	Auteur Author	Modifications		
Conception Design		GM	Désignation / Designation <b>PLAN D'INTERFACE</b>  Référence / Reference <b>IN-PRO-334</b>		
Vérification Checking		YN			
Tolérance Tolerance		ISO 2768mK			
Echelle Scale	1:2		Matière / Material	Traitement / Treatment	Finition / Finish
		Format A4	Ce document est la propriété de A.A.SA. Il est strictement interdit de reproduire ce document ou une partie sans l'autorisation de A.A.SA. This document is the property of A.A.SA. It is strictly prohibited to reproduce this document or a part without the authorization of A.A.SA.		
			Folio / Sheet 1/1	Indice / Index A	



A.A. SA OPTO-ELECTRONIC DIVISION  
 18, rue Nicolas Appert  
 F-91898 ORSAY  
 tel : 08 11 09 76 76  
 fax : 01 76 91 50 31